

TECHNICAL CARD

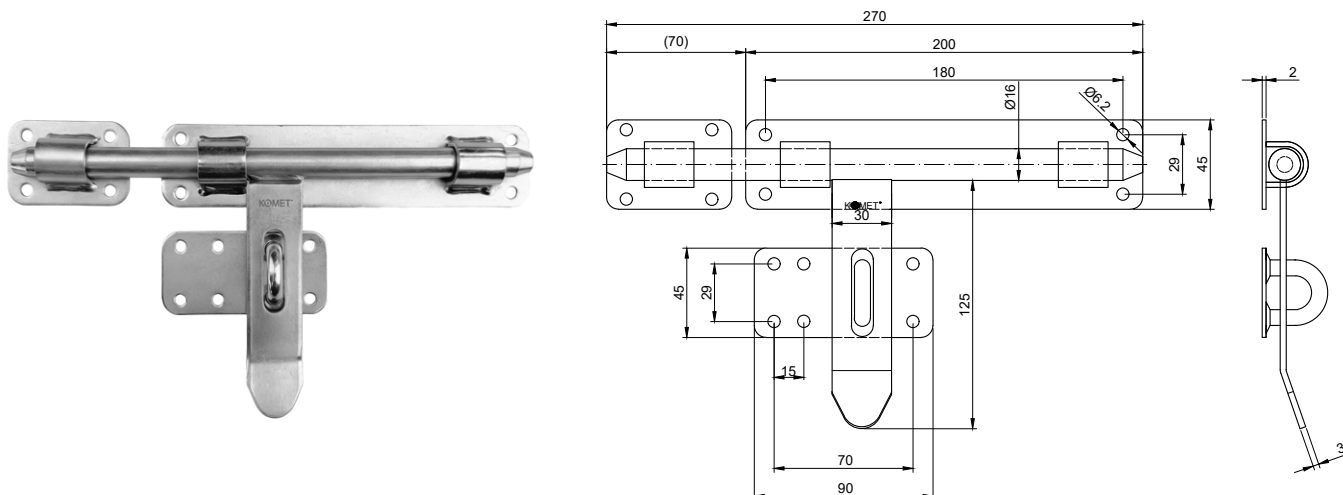

PRODUCT NAME
Slide bolt 270 galvanized, base 45 mm

ITEM CODE
30.104

EAN
5901431940338

TECHNICAL DATA
Material – S235JR steel
Weight of 1 pc – 0.90 kg
Coating – galvanic zinc
Color – white zinc

APPLICATION

The slide bolt is used for fitting fencing and garage doors and gates. The lock locks the gate leaves and enables protection with a padlock against opening.

The product has a **National Technical Assessment** issued by the Building Research Institute,
No. ITB-KOT-2025/2977, Issue 1

PRODUCER
KOMET
A.J. Bujak K. Grymel-Bujak s.c.

NOTES: All technical data are approximate values. The manufacturer reserves the right to correct the product and change the technical conditions with the possibility of making changes inside the specification. This information cannot be considered as a guarantee, nor is it legally binding in any way.

